

## Another RX with IC-7700 by IW0HEX Pasquale

Hi

I put pictures of my project. This circuit allows you to connect to another IC-7700 radio used as a receiver. In this way we have 2 independent receivers.

Everything is handled by this circuit from PTT (for any amplifier), the BF and of course the splitter to the RF circuit.

The BF is very interesting because part of the signal, taken from Radio 2, can be processed in 4 ways to get it through headphones or

- 1) Only main radio
- 2) Only radio sub
- 3) The 2-channel in stereo headphones
- 4) Mute

these are some photos



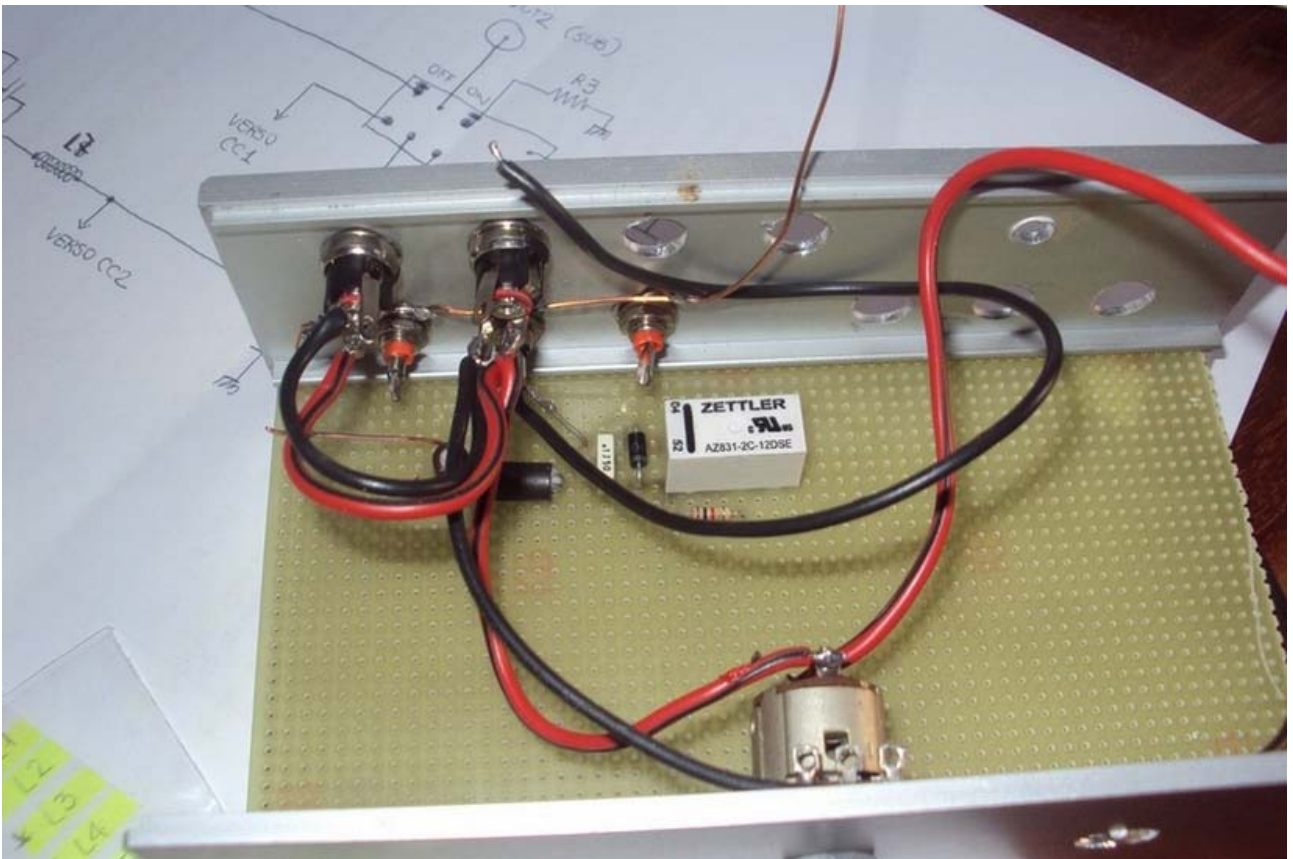
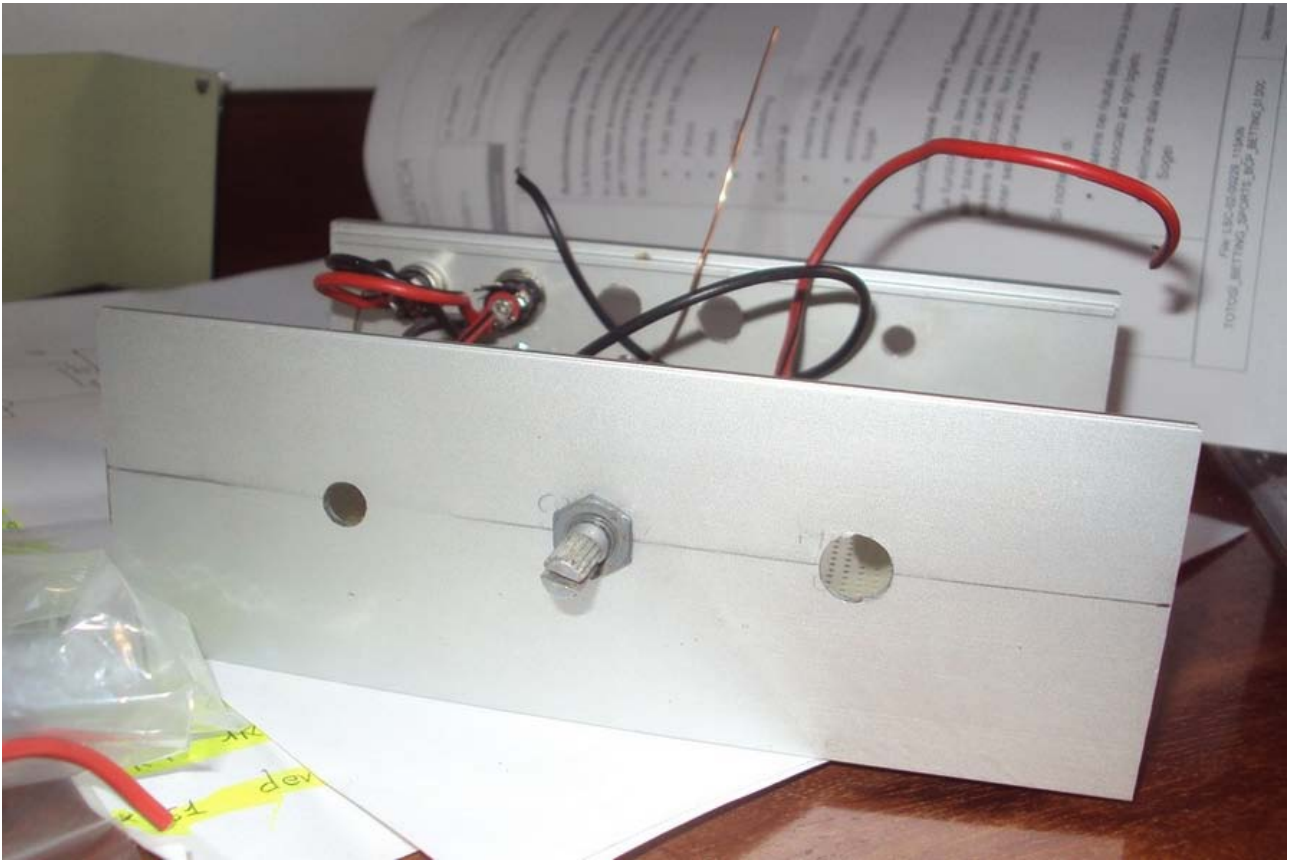

In my case as a second radio (Radio B) using an IC-7400.

This is a practical example of the operation: I use IC-7400 (Radio B) to receive the DX station so it works only RX, fixed on the frequency of the DX station.

With the IC-7700 (Radio A), instead, used for TX (radio operates inside the TX / RX switching to the second RX), I follow the stations that called in the pile-up.

So you always use one VFO on each radio.

I make some clarifications: You can not swap the 2 radios. The IC-7700 is used only in TX because it has the TX/RX circuit that switches the signal to the splitter; infact during TX IC-7700 bypass the splitter. With IC-7400, not having a dedicated output to double-RX, it is not possible.

The circuit of the splitter is taken from the following site

<http://www.qrp.pops.net/swl-ant-split.asp>









In this picture here is the finished circuit. Even my cat (Mina) seems to appreciate the advantages of having a second receiver, hi. Note that in the first picture I put a potentiometer for determining the af-level with stereo headphones, but then I noticed that this control is not needed, the af can be dosed by radios. Instead of the potentiometer I put a red LED that indicates when the circuit is in TX.



Here is the wiring diagram of the circuit, divided into 2 parts (diagram 1 and 2).

The first part is the circuit for low frequency ( af ), the second part is the splitter circuit and the switching of the PTT.

Explanation:

As I said before radio A is the radio used to transmit IC-7700, the radio B is used to receive the radio IC-7400.

I depart from the first scheme that covers the af-signals.

As you can see there are 4 relays', 3 are used for the 3 combinations (radio A rx, radio B rx, listening radio A/B in the stereo headphones), the relay 4 is to use the headset in mono mode (cases 1 and 2) or in stereo mode (case 3).

Diagram 1

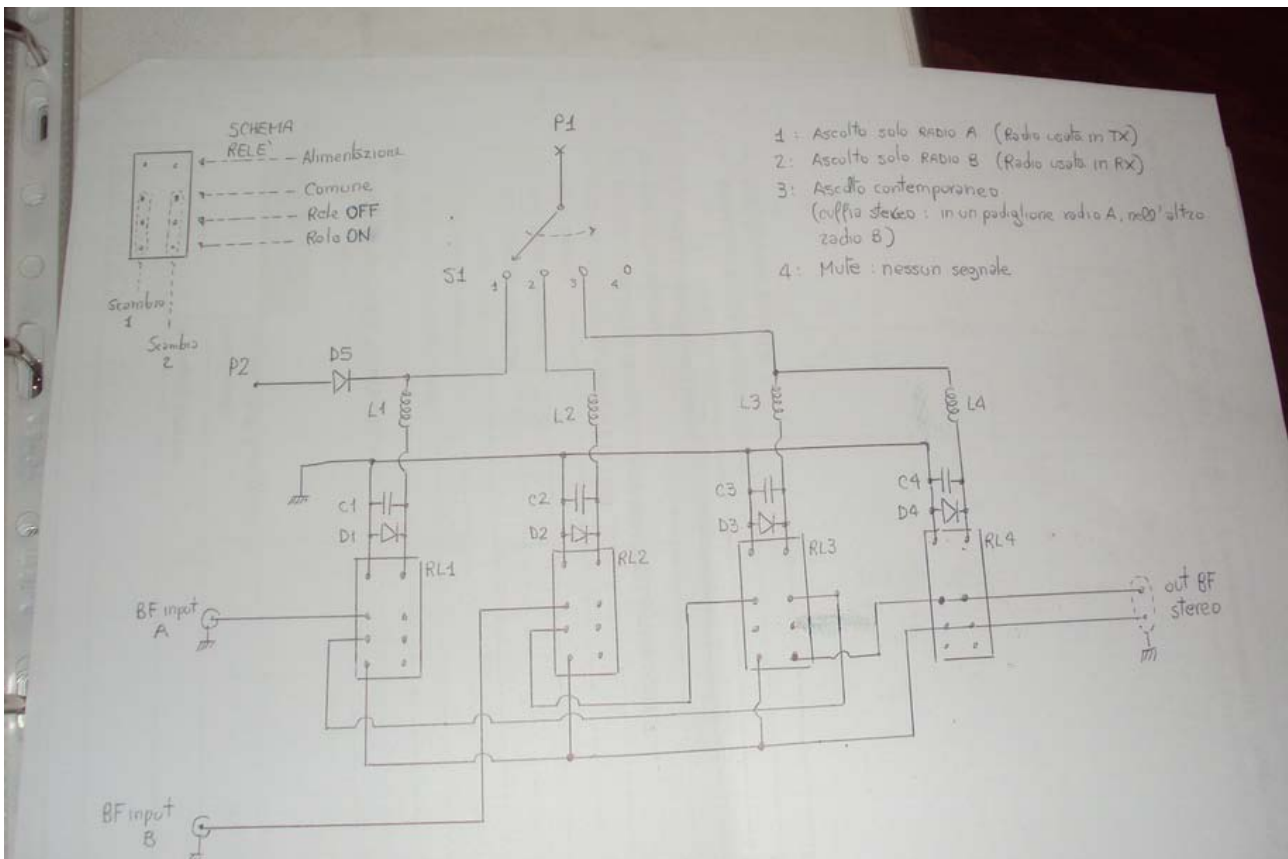

In fact, when you listen to every single radio (A or B), the signal must go to both ears of the headphones; when you listen together one ear is for radio A, the other one is for the radio B.

P1 is the common 4-position switch. On P1 there is 12 volts when the radio A is receiving. When the radio A is transmitting, the switch is not powered, so no relay (apparently) receives 12 volts, I say apparently because in reality during the transmission phase, the relay 1 is switched on through the diode D5 . This will be understood better after when we see diagram 2.

We return to our diagram 1: when the radio A is receiving, there are 12 volts on P1. So with the switch, we feed one of 3 relays'.

If S1 is on 1 position : relay 1 is on , relays' 2, 3 and 4 are off. AF signal input is for radio A. In both the headphones have the same output signal (from radio A).

If S1 is on 2 position : relay 2 is on , relays' 1, 3 and 4 are off. AF signal input is for radio B. In both the headphones have the same output signal (from radio B).

If S1 is on 3 position : relays' 3 and 4 are on , relays' 1 and 2 are off. In both the headphones have 2 signals from radio A and from radio B. In this situation we listen 2 radios with headphones.

If S1 is on 4 position : relays' 1, 2, 3, 4 are off. No signal in output. Mute position.

The diodes that you see in the diagram are 1N4007, polyester capacitors 100,000 pF, the inductance VK200; it all needs to avoid RF trouble. The relays are all double exchange, 12 volts.

Diagram 2

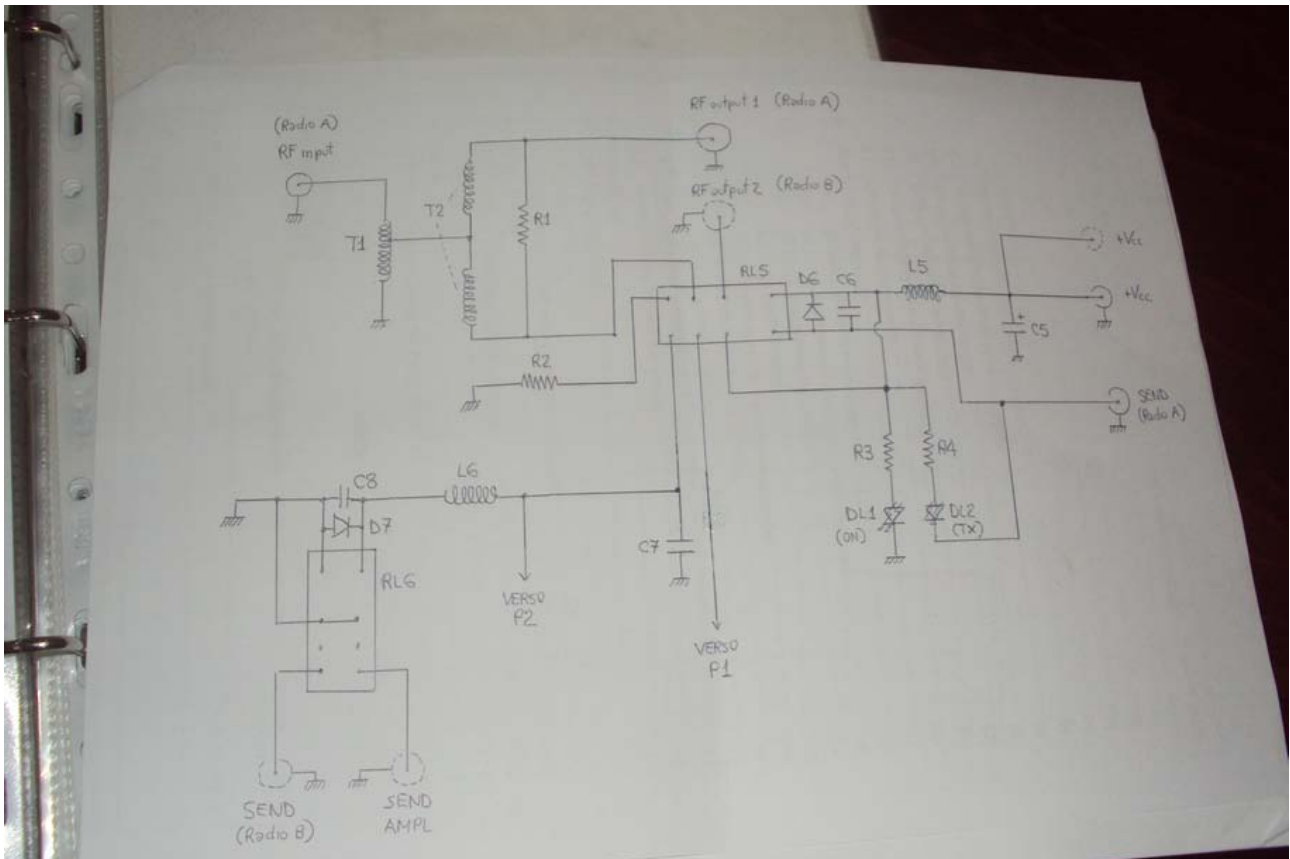

Now diagram 2:

The relay 5 (RL5) is switched ON by radio A SEND. Power is taken from the radio A, the canonical 12 volts (I split the power supply because I have the Power Master wattmeter too).

When the radio A is in RX, RL5 is OFF. This means that the port 2 of the splitter is connected to the splitter circuit (T1, T2 and R1) and 12 volts goes to the switch as I described above (see P1).

When the radio A is in TX (by SEND A to ground), it happens that RL5 is ON. The radio B is then connected on a 50 ohm load (see R2), to avoid any problems (although I have to unplug the microphone from IC-7400 and closed RF power to zero).

Simultaneously, the switch S1 (diagram 1) does not receive more than 12 volts; but 12 volts, through P2, power supply to the relay 1 through the diode D5, mentioned earlier. In addition, the RL6 is used to send TX a linear amplifier and the radio B (SEND AMPL and SEND RADIO B)

Why relay 1 must go ON during transmission?

Imagine this situation: I'm in the pile-up, switch to position number 3, listen to both radios. The radio A has the monitor function is ON so I can listen myself during my TX.

When I receive no problem, I listen in my headphones both radios, A and B. But during my TX, I hear my monitor only in one headphone, a very unpleasant sensation!! With relay 1 on during TX, I listen myself well in both headphones !!!

DL1 and DL2 LED diodes are used respectively to indicate when the circuit is ON and when you go in TX.

All values of capacitors, diodes and inductors are like those of diagram 1, except:

R1 = 100 ohm 1 / 2 watts

R2 = 50 ohms 2 watts

R3 = R4 = 1000 ohm 1 / 4 watt

C5 = 1 uF electrolytic, 25 volts

T1 = 10 turns on FT50-43 toroid with power to the third loop. The third loop is counted from the hot pole.

T2 = 10 turns bifilar on FT50-43 toroid.

For any question, send my a email :

[iw0hex@email.it](mailto:iw0hex@email.it)

Best 73s de IW0HEX Pasquale.